

REV.	ECN NO.	LOCAS.	DESCRIPTION	DATE	DESIGN
A					HANG
B					HANG

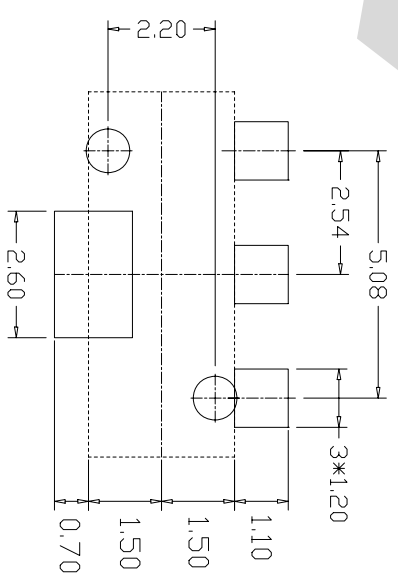

Recommended P.C.B. LAYOUT

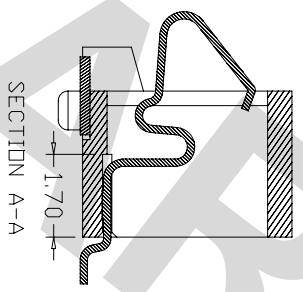
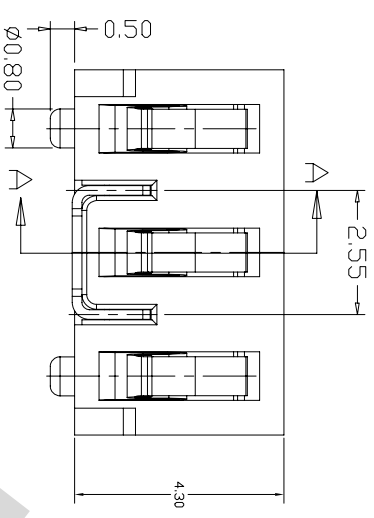
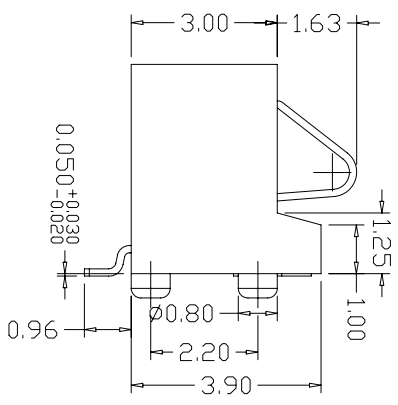
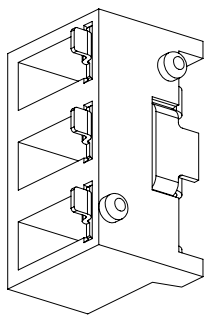
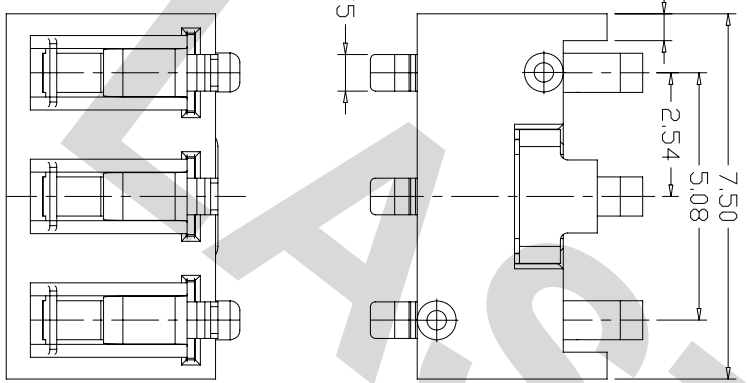

- MATERIAL**
- Housing: Thermoplastic, UL94V-0, 30%G/F Filled, Color Black
 - Contact: 5U" Gold Plating On Contact Area
G/F Plating On Soldertails
50U"Min Nickel Under Plating Over All

LASTAR

Lastar Technology CO., LTD

DRAW NO.	254-43B-03	DATE	070506	DRAW NAME:	Battery Conn Pitch2.54 3Pin 4.3KType T)
DESIGN	HANG	070505		P/N NO.	BCM-254-43B-0319-T
CHECK	WANGCH	070506		UNIT:	mm
APPROVED	HUYX	070506		SHEET:	N/A
				MODEL:	
				REV. AO	SCALE N/A